

Rev. D Changed Note 3 to call out CeramTB062618revG. Increased copper pin diameter. 062618 BS

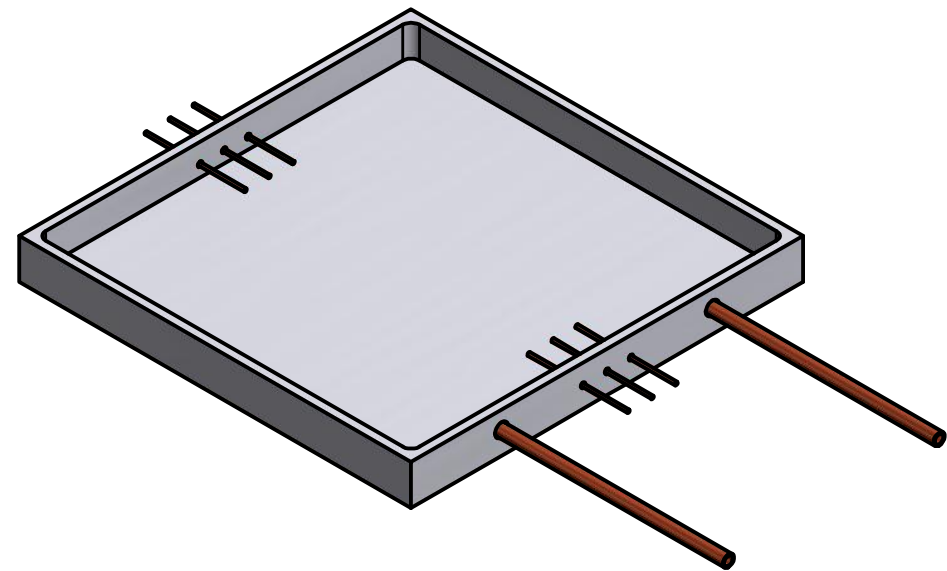

Notes-

1. Tile base assembly consists of the tile base, two OFHC copper tubes, and six copper pins.
2. Tile base as specified in Univ.of Chicago print CeramTB062618revG.
3. The copper tube must be OFHC tempered appropriately to be hermetically sealed with a pinch-off cold weld.
4. The Base Assembly after brazing tubes and pins to be hermetic in helium leak-test at UC to $5 \times 10E - 10$ cc/sec.

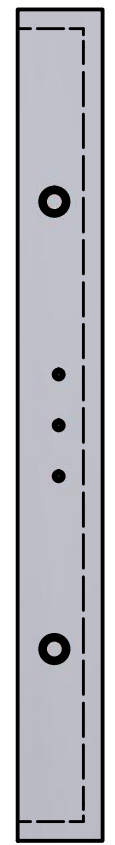
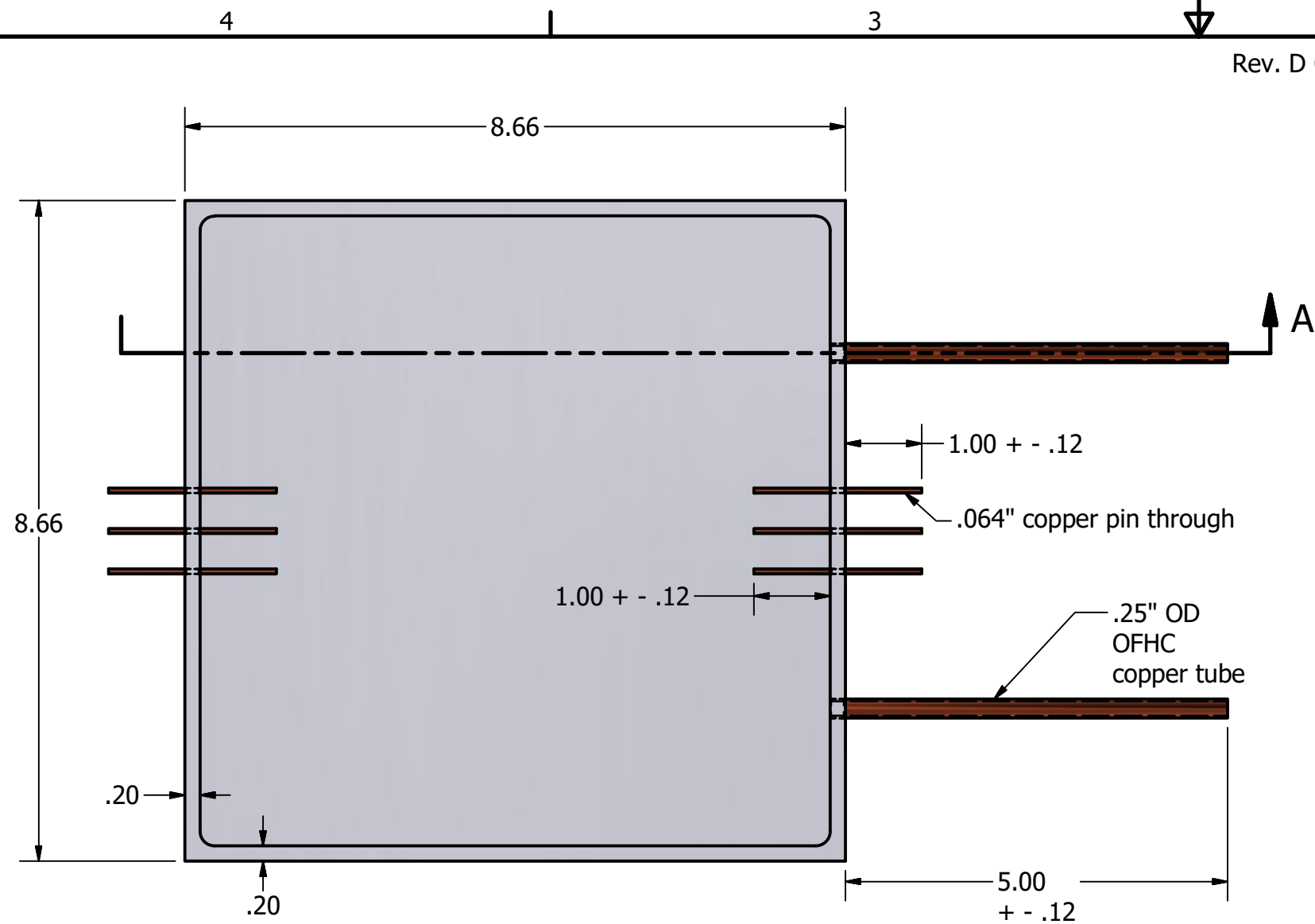
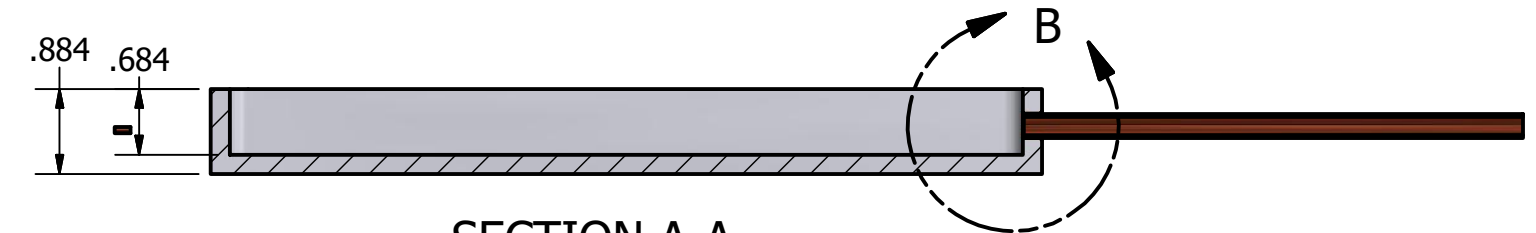

SECTION A-A

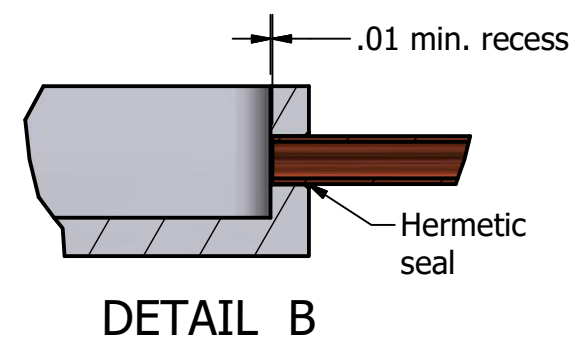

DETAIL B

DRAWN rnorthrop	3/22/2017	University of Chicago		
CHECKED				
QA		TITLE		
MFG		Type E Green Trim Ceramic Tile Base Assembly - Vendor E		
APPROVED		SIZE B	DWG NO CeramTBAssm062618revD	REV D
		SCALE	SHEET 1 OF 1	