

Notes-

1. Welding must pass a helium leak-test to  $5 \times 10^{-10}$  Torr · L / Sec
2. Welding joint design TBD by fabricator.
3. All dimensions are inches.

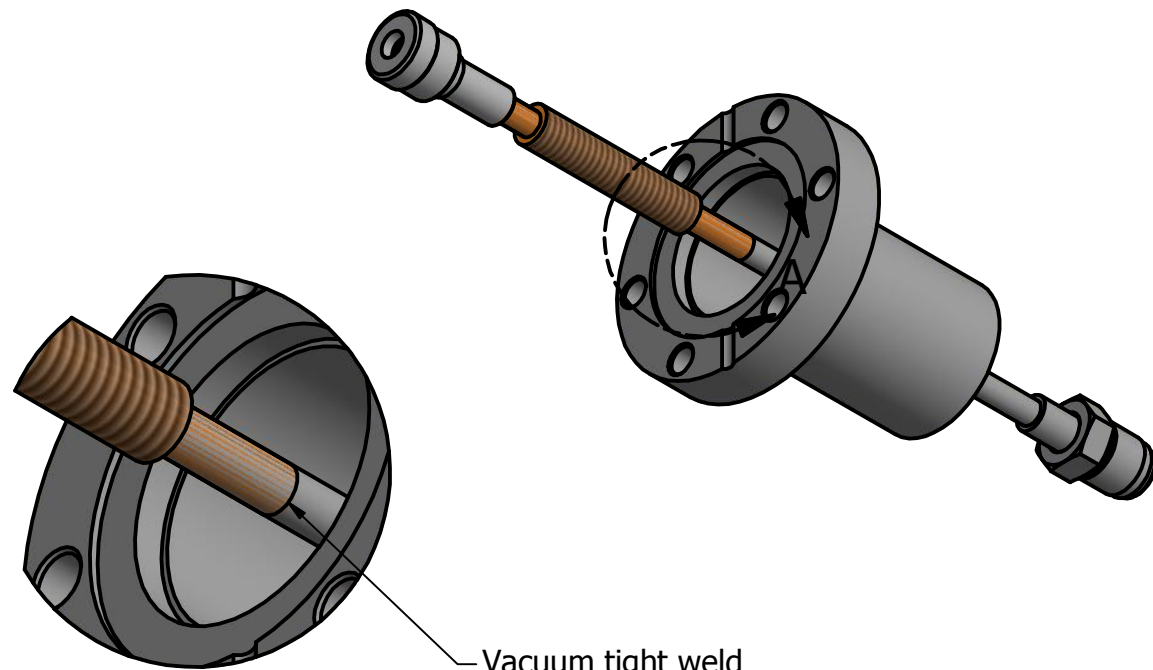

Vacuum tight weld  
Joint design TBD by fabricator

DRAWN rnorthrop	10/2/2017	University of Chicago		
CHECKED		TITLE		
QA		Vacuum Vessel Port Detail		
MFG		SIZE	DWG NO	REV
APPROVED		B	VacPortTypeB100217	
		SCALE	1 : 1	SHEET 1 OF 1