

Notes-

1. Material - Stainless steel T-304
.75 Dia. rod stock
2. 10 Req'd.
3. Tol. .xx +- .020
.xxx +- .010
except as noted

DRAWN rnorthrop	3/20/2017	University of Chicago		
CHECKED		TITLE		
QA		Pusher Disc Detail		
MFG		SIZE	DWG NO	REV
APPROVED		B	PusherDisc32017	
		SCALE		SHEET 1 OF 1

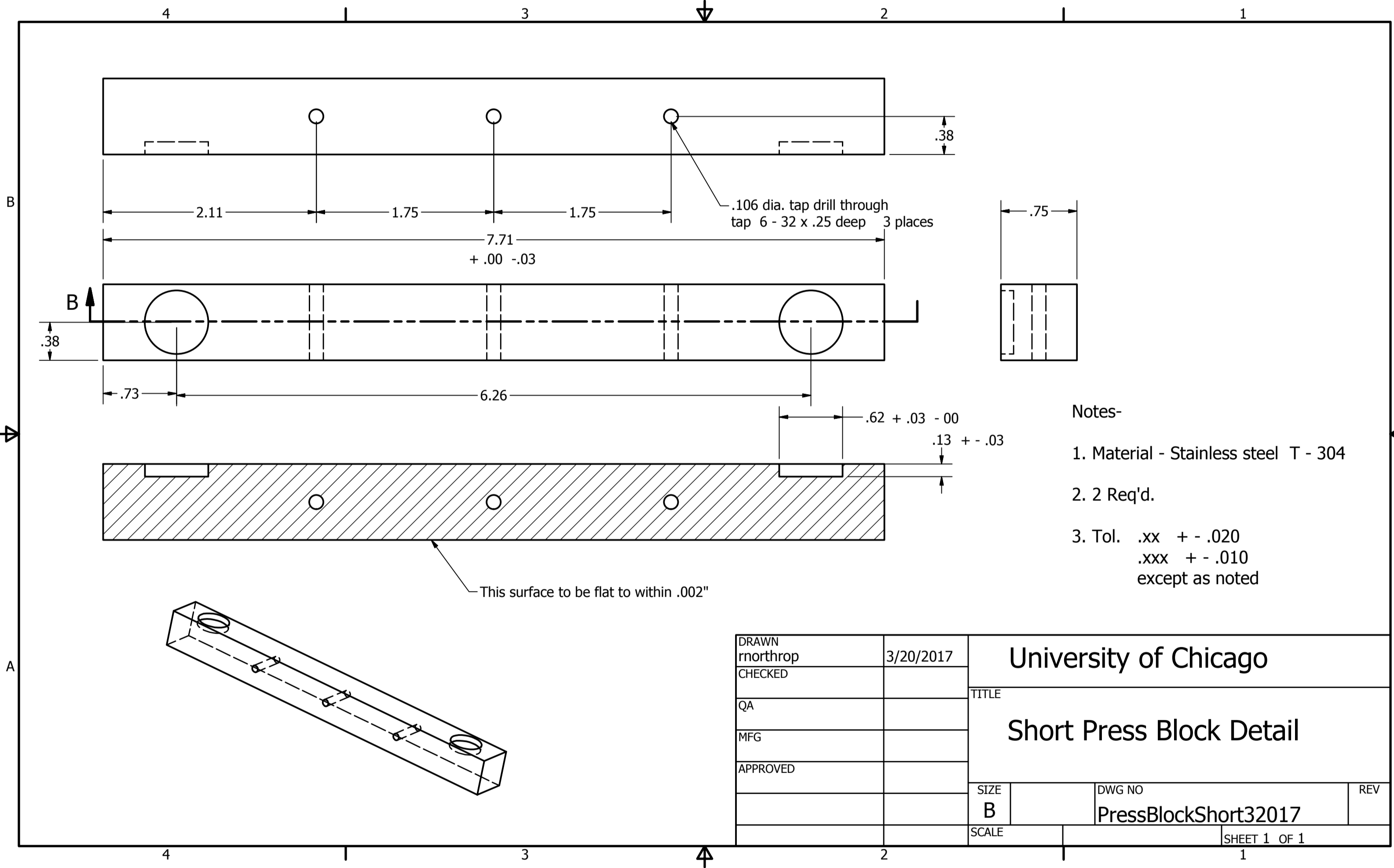

Notes-

1. Material - Stainless steel T - 304
2. 2 Req'd.
3. Tol. .xx +- .020
.xxx +- .010
except as noted

DRAWN rnorthrop	3/20/2017	University of Chicago		
CHECKED		TITLE		
QA		Short Press Block Detail		
MFG		SIZE	DWG NO	REV
APPROVED		B	PressBlockShort32017	
		SCALE		SHEET 1 OF 1

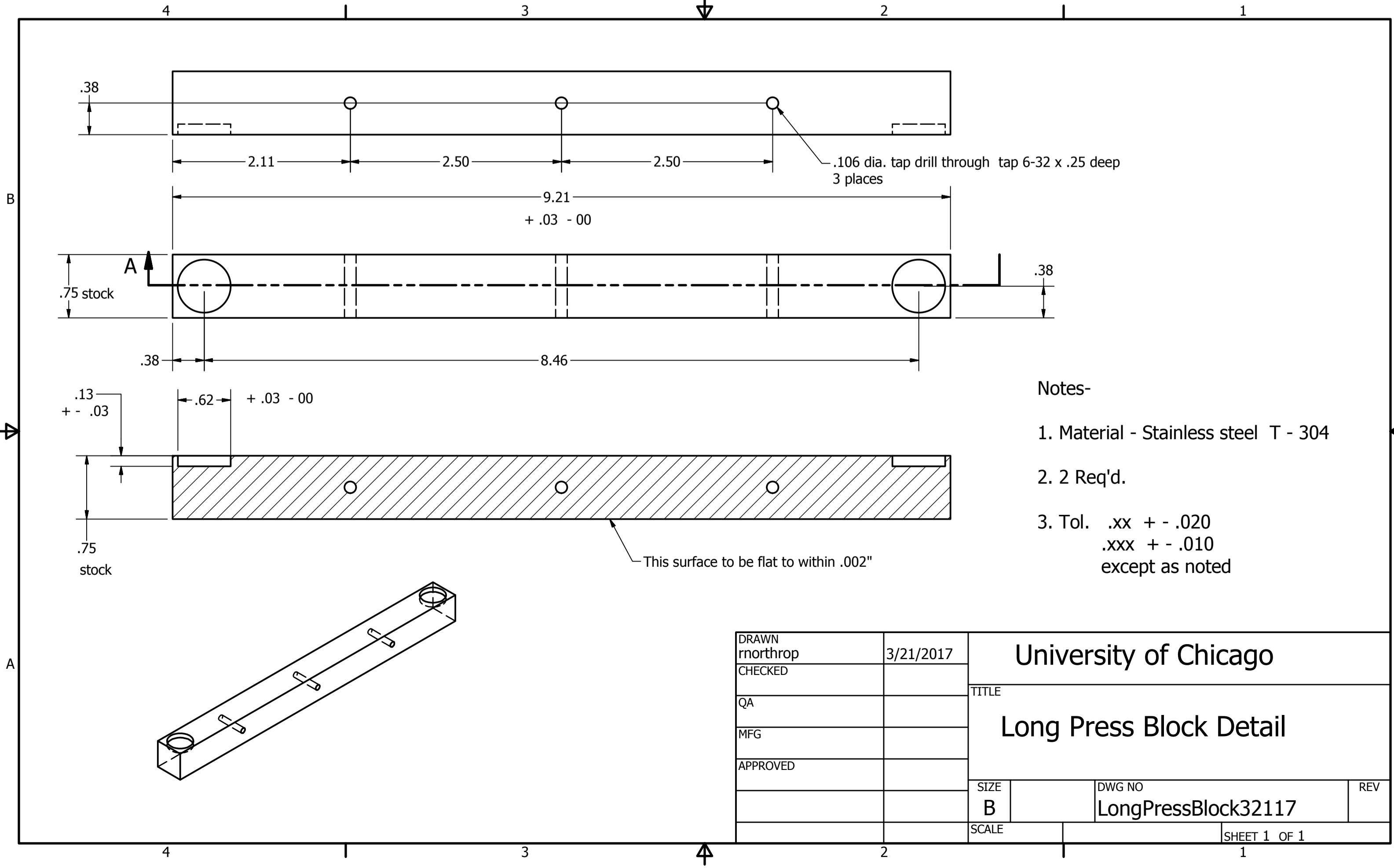

Notes-

1. Material - Stainless steel T - 304
2. 2 Req'd.
3. Tol. .xx +- .020
.xxx +- .010
except as noted

DRAWN rnorthrop	3/21/2017	University of Chicago		
CHECKED		TITLE		
QA		Long Press Block Detail		
MFG		SIZE	DWG NO	REV
APPROVED		B	LongPressBlock32117	
		SCALE		SHEET 1 OF 1