

Rev.A Increased pin lengths to 1.0 + - .12 & added + - .12 tol. to tube length 3.21.17 RN

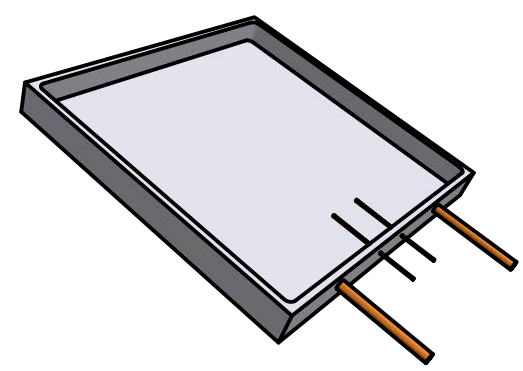

Notes-

1. Tile base assembly consists of the tile base, two OFHC copper tubes, and two copper pins.
2. Tile base as specified in Univ. of Chicago print Dwg # CeramTB111015.
3. The copper tube must be OFHC tempered appropriately to be hermetically sealed with a pinch-off cold weld.
4. Tile Base Assembly after brazing tubes and pins to be hermetic in helium leak-test at UC to $5 \times 10E - 10$ cc/sec.

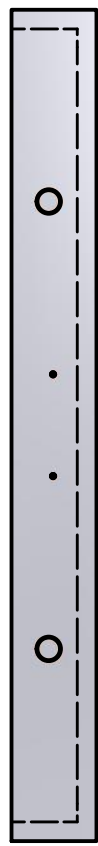
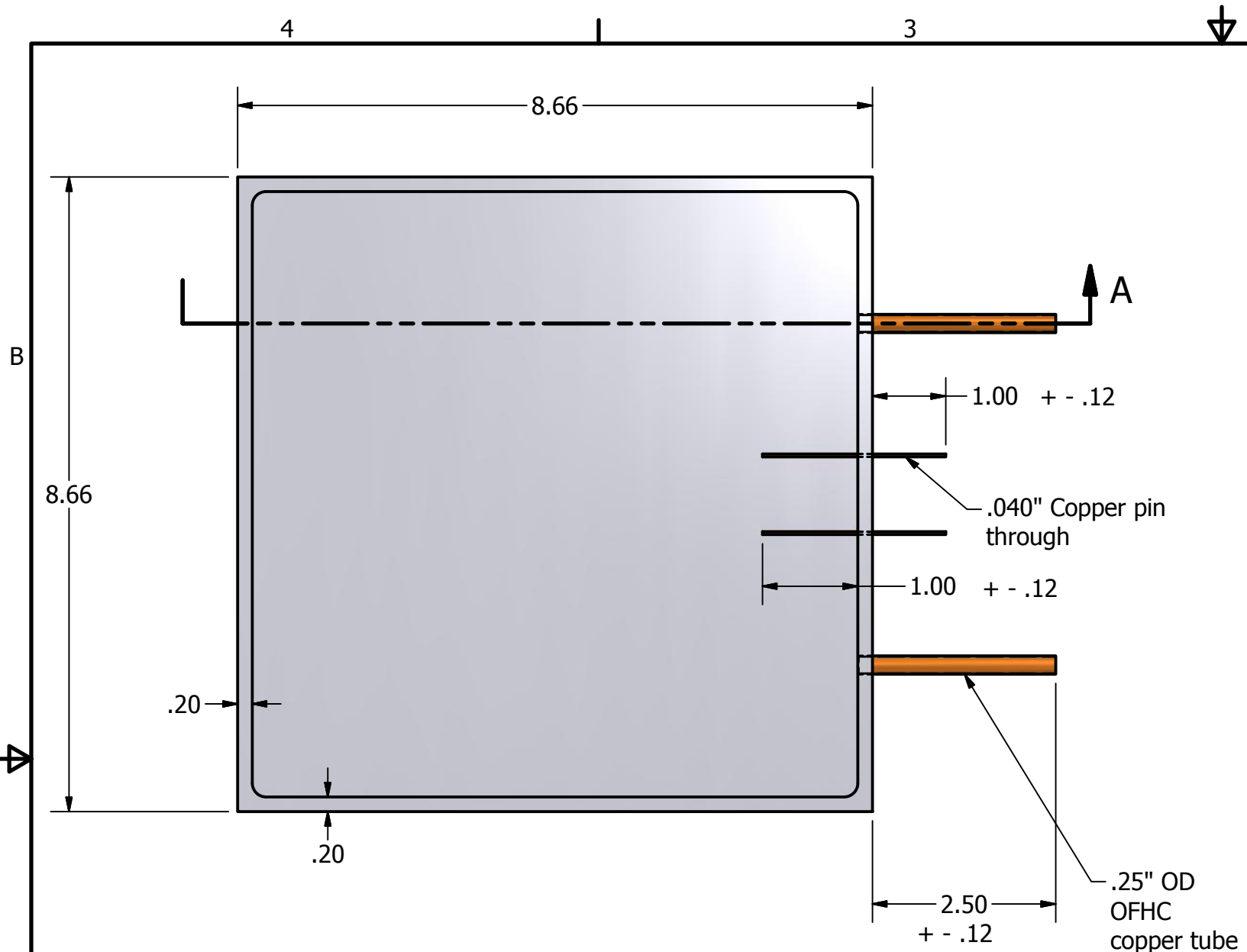
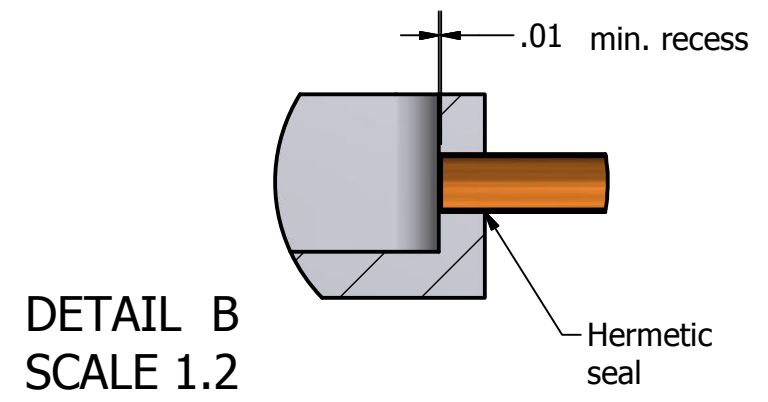
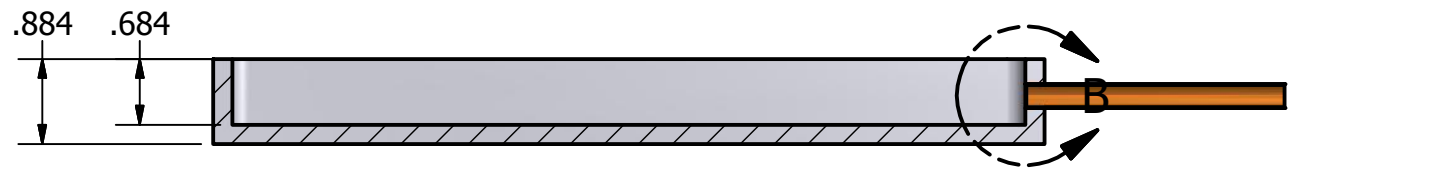

DRAWN rnorthrop	3/22/2017	University of Chicago		
CHECKED		TITLE		
QA		Type C - Green Trim Ceramic Tile Base Assembly		
MFG		SIZE B	DWG NO CeramTBAssm081015revA	REV A
APPROVED		SCALE	SHEET 1 OF 1	