

4 3 2 1

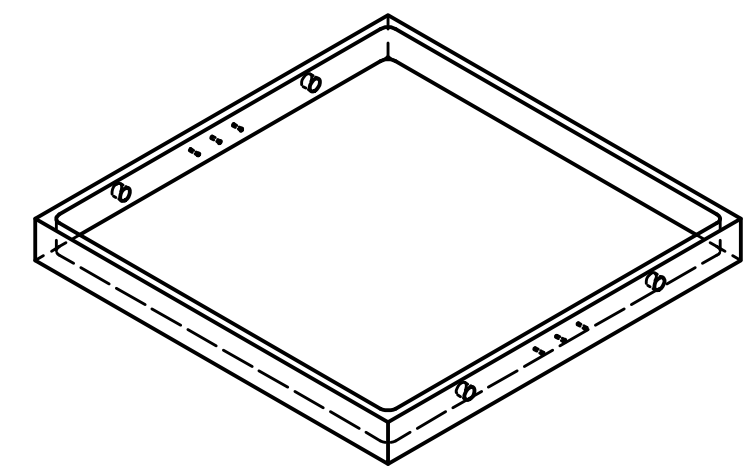

Top surface to be flat and parallel to top surface of base to within 0.005"

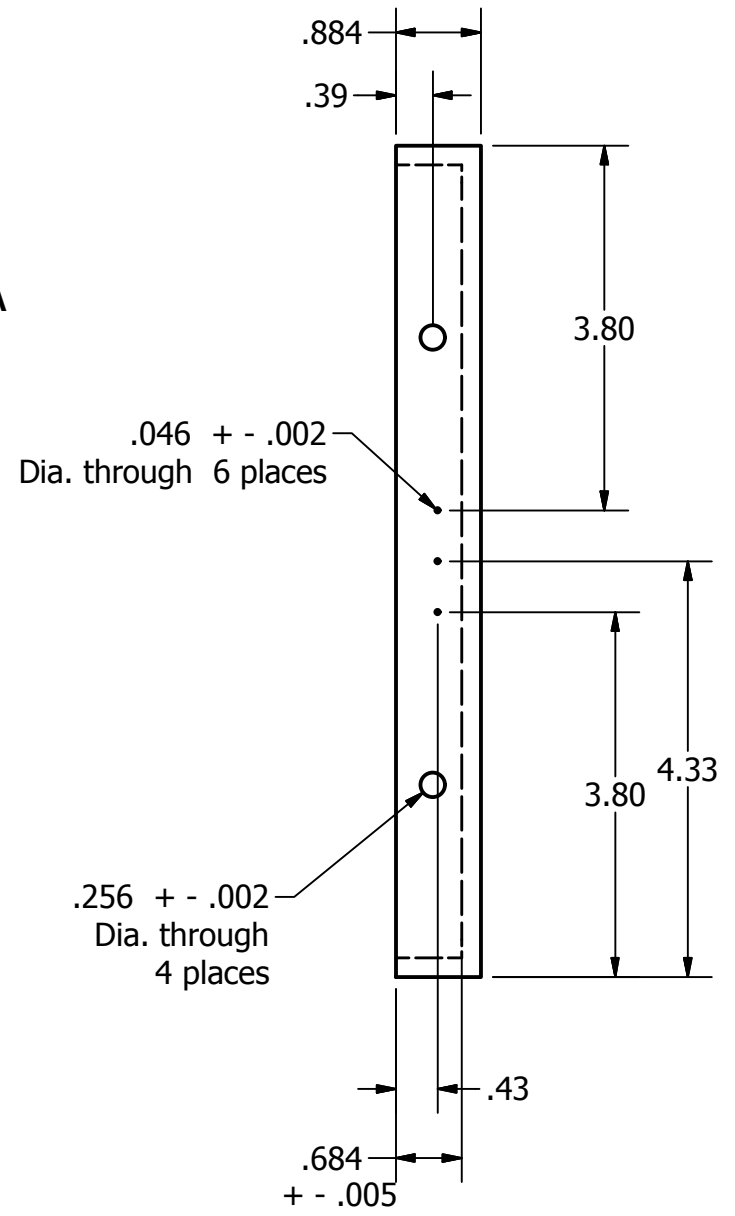
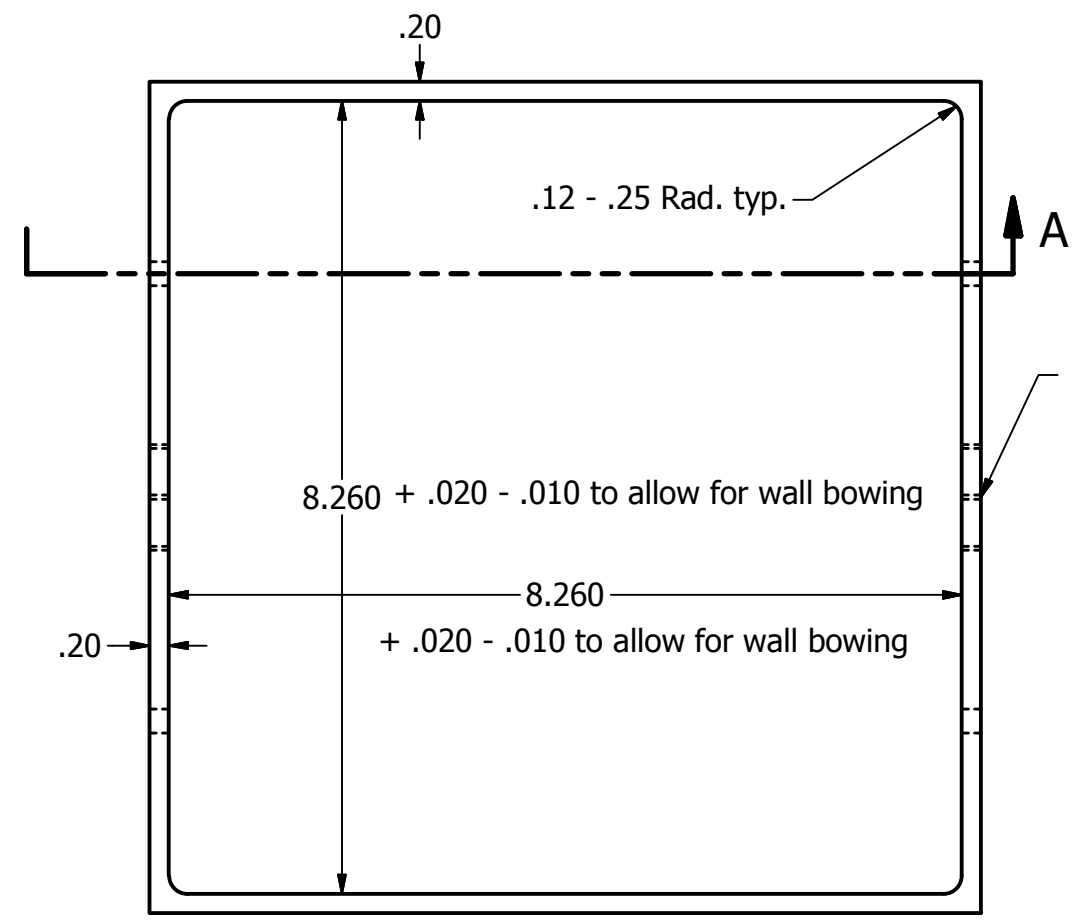

SECTION A-A

Wall tilt allowable if top surface is flat and parallel to base

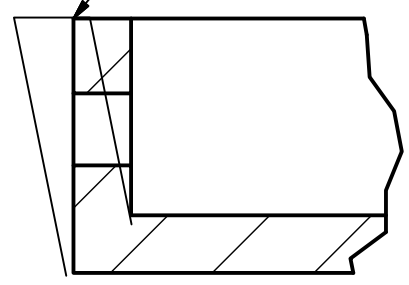

DETAIL B

Notes-

1. Tile base to be made of full-fired alumina 96% pure or higher.
2. Tile base to be hermetic in helium leak-test at UC to $5 \times 10E - 10$ CC/SEC.

DRAWN rnorthrop	1/11/2017	University of Chicago		
CHECKED		TITLE		
QA		6Pin 4Tube Tile Base		
MFG				
APPROVED				
		SIZE B	DWG NO 6Pin4TubeTB011317	REV
		SCALE	SHEET 1 OF 1	

4 3 2 1