

4 3 2 1

D  
C  
B  
A

D  
C  
B  
A

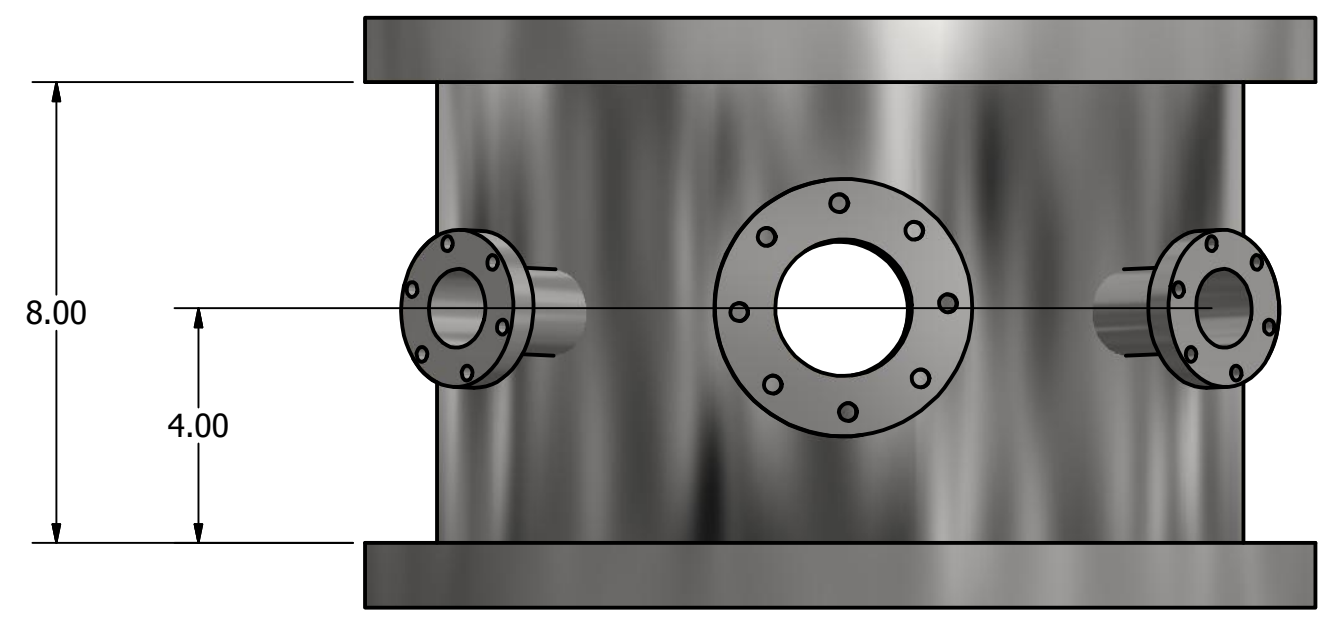
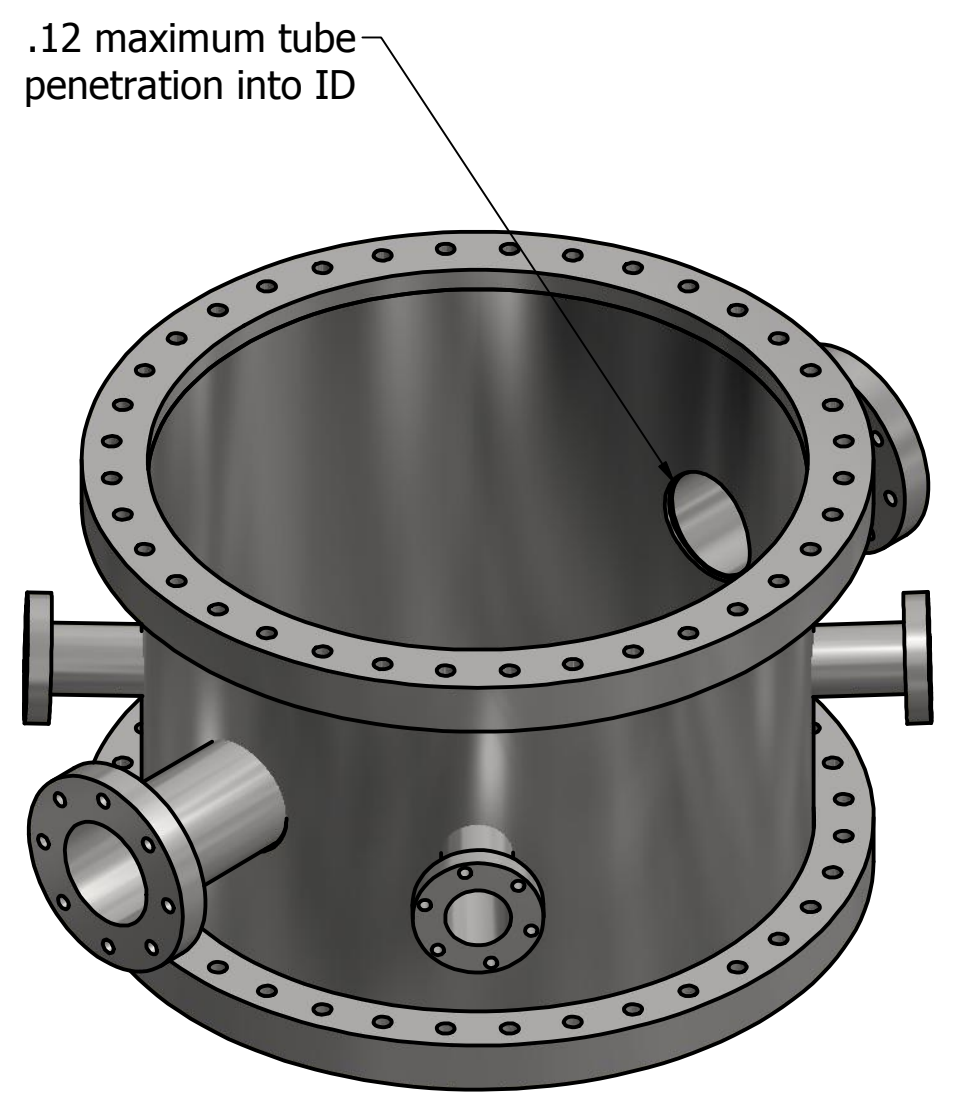
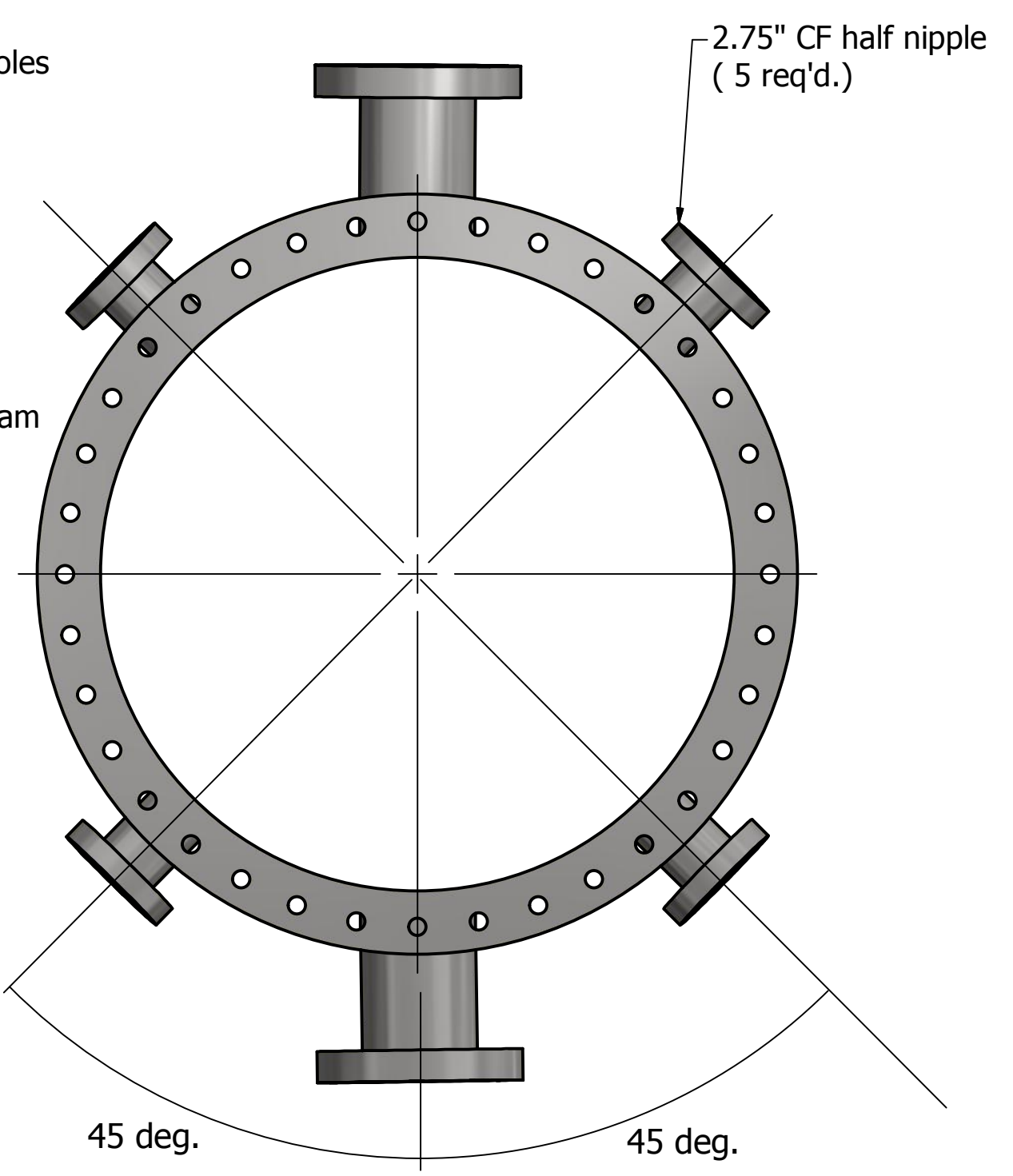
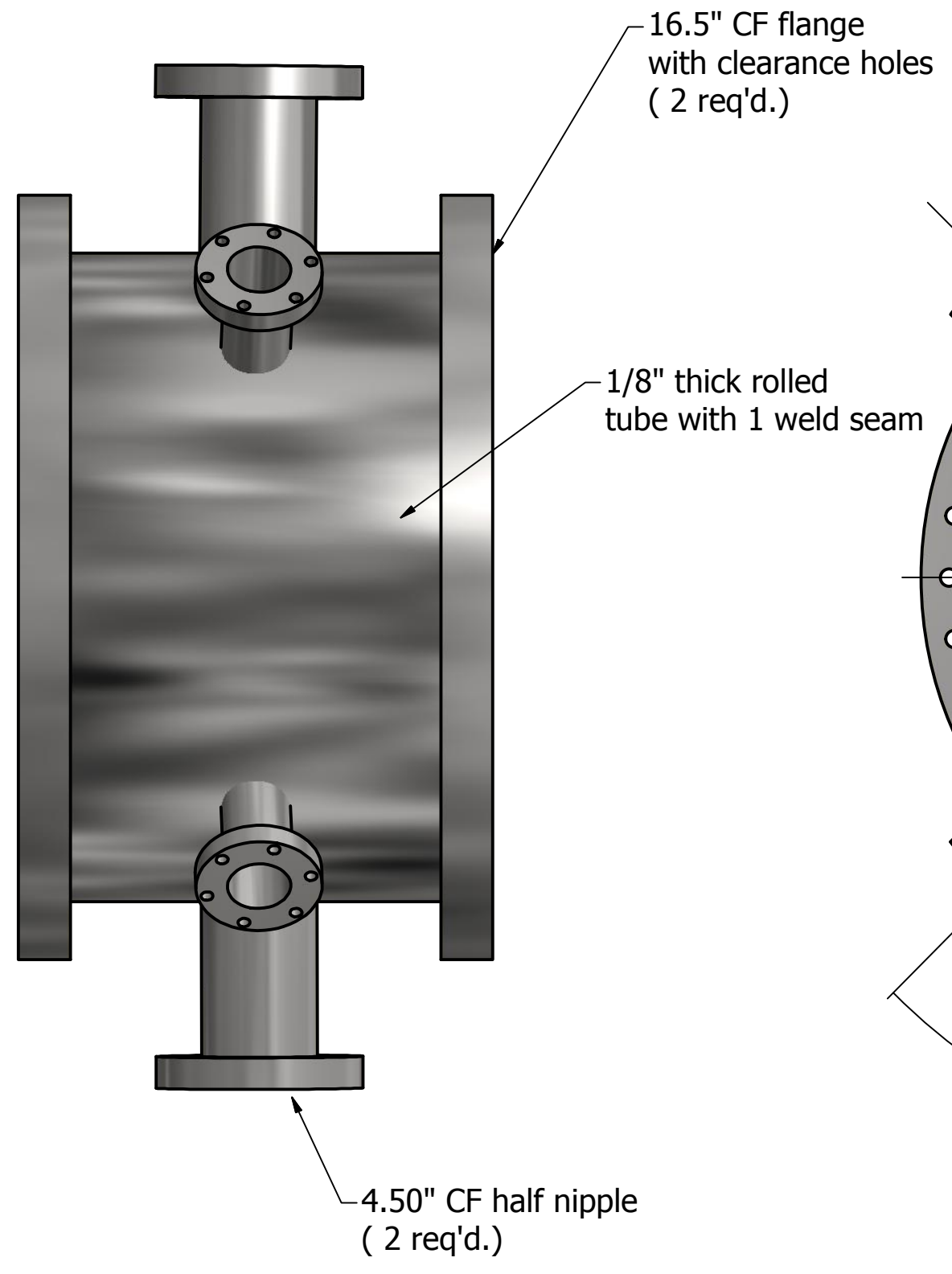

Notes:

All material to be stainless steel T-304

1 Req'd.

Tolerance + - 1/16"

Welding must pass a helium leak-test to  $5 \times 10E - 10$  cc / sec.

|                    |           |                           |                        |     |
|--------------------|-----------|---------------------------|------------------------|-----|
| DRAWN<br>rnorthrop | 12/5/2016 | University of Chicago     |                        |     |
| CHECKED            |           | TITLE                     |                        |     |
| QA                 |           | Multi port Vacuum Chamber |                        |     |
| MFG                |           | SIZE                      | DWG NO                 | REV |
| APPROVED           |           | C                         | MargheritaTwo12_5_2016 |     |
|                    |           | SCALE                     | SHEET 1 OF 1           |     |

4 3 2 1