

Metalized top surfaces
200 nm of NiCr

3/8 OD X 1/4 ID
Ceramic tube
(through)

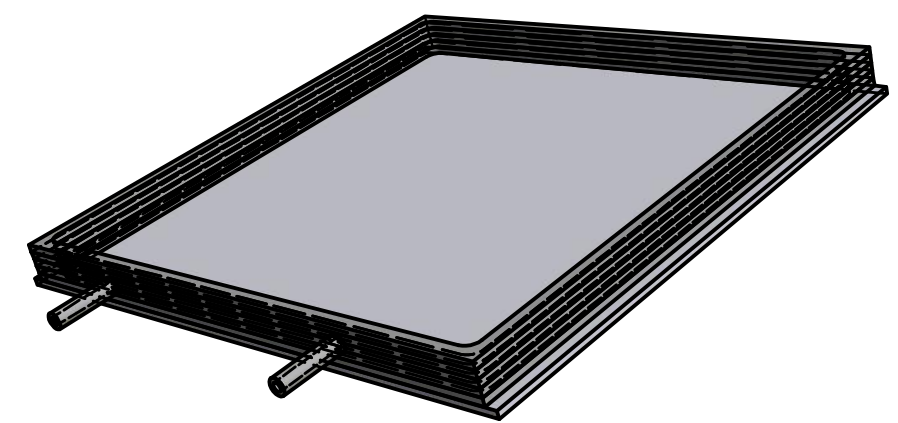

Notes-

1. Material- Alumina of 96% purity or greater (e.g. Coorstek ADS-96R).
2. Cut tol. + - .005.
3. Sidewall can be made of a number of brazed layers as shown or a monolithic casting then brazed to bottom plate.
4. Layers to be brazed together with each layer forming a hermetic seal.
5. Sidewall to be free of metal inside and out.

DRAWN rnorthrop	6/1/2015	University of Chicago		
CHECKED				
QA		Ceramic Tile Base Assembly		
MFG				
APPROVED				
		SIZE B	DWG NO CeramicTileBase	REV
		SCALE	SHEET 1 OF 1	